

# Thermal printer mechanism

*TP485A-H* serial

All reserves the right to make changes without notice to the specification and materials contained herein and shall not be responsible for any damage ( including consequential ) caused by reliance on the materials presented, including but not limited to typographical, arithmetic, or listing errors.

# Content

CHARACTERS AND OPERATING PRECAUTIONS .....	3
1. Characters .....	3
2. Operation precautions .....	4
CHAPTER 2 SPECIFICATIONS .....	5
2.1 General specifications .....	5
2.2 Heat element dimensions .....	6
2.3 Paper feed characteristics .....	6
2.4 Step motor characteristics .....	6
2.4.1 Step motor specifications .....	7
2.4.2 Excitation sequence .....	7
2.4.3 Step motor driving .....	7
2.5 Thermal head specifications .....	7
2.5.1 General characteristics .....	7
2.5.2 Maximum parameter .....	7
2.5.3 Characteristics recommended .....	8
2.5.4 Electrical characteristics .....	9
2.5.5 Timing characteristics .....	10
2.5.6 Timing figure .....	10
2.5.7 Equation: .....	11
2.5.8 Circuit recommended .....	11
2.5.9 Thermistor resistance .....	12
2.5.10 Structure figure .....	13
2.5.11 Operating precautions .....	13
2.6 Tables .....	14
2.7 Photo interpreter specification .....	15
CHAPTER 3 CASING DESIGN GUIDE .....	18
3.1 Thermal printer mechanism structure dimensions .....	18
3.1.1 Easy paper loading dimensions .....	18
3.1.2 Roll-paper mounting position .....	19
3.2 DEMO circuit figure .....	20

---

## Characters and operating precautions

### 1. Characters

#### Model definition

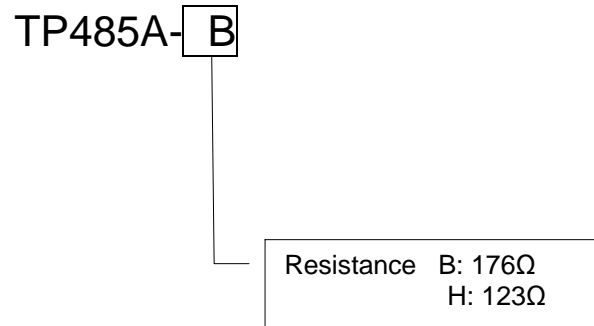

#### 1. Low voltage supply

The voltage used to drive the thermal printer head is equal to the logic voltage, or is driven by a 5 V single power line, the range of operating voltage is 4.2V-8.5V, so four to six NI-Cd batteries or Ni-MH batteries can also be used. Two li-ion battery can be used.

#### 2. Low volume Compact and light

The mechanism is compact and light, dimensions: 67.4mm(width) \* 30.8mm(depth) \* 32.2mm ( height )

#### 3. Printing with High resolution

A high-density printer head of 8 dots/mm make the printing clear and precise

#### 4. High speed printing

According to driving power and sensitivity of thermal paper, set different printing speed required . Max printing speed is 70 mm/ sec.

#### 5. Easy paper loading

Detachable rubber roller structure make the paper loading easier

#### 6. Low noise

Thermal line dot printing is used to guarantee low-noise printing.

## 2. Operation precautions

1.1 When handling this printer, for TPH and photo interpreter is sensitive to static electricity, please take any preventive measures against static electricity, such as disposable static wrist strap, in order to prevent damages of inner parts of the printer caused by the static electricity.

When attaching the platen part to the platen retainer, pay attention not to flaw or damage or smear the rubber part of the platen, the platen gear, and the bearing part ( particularly , don't attach any oil or grease and foreign materials on the rubber part .

1.3 Never attempt to touch the thermal printer head surface with bare hands . Attaching any oil or grease such as oils from palms on the heating element part of may be shorten the lifetime of the thermal head. In case that any oil and grease or foreign materials are attached on it. Perform the cleaning immediately . In addition, pay attention not to hit it with something hard such as driver.

1.4 When assemble the platen to the platen retainer of the casing , make sure that the orientation is correct.

1.5 The thermal head and FPC are shipped as they are connected. When installing the printer, do not pull or apply any extra force in order to avoid the connected part of the thermal head and FPC from being disconnected or deviated. When connecting FPC, please make it sure under condition that the power of control circuit is off. Plug in / out FPC to control board, should less than 10 times , meanwhile make FPC parallel to connector socket.

1.6 Do not make FPC bend because it may cause FPC disconnection or broken. If FPC requires to be bent, it will be rework if the bending more than R1.

1.7 The printer has a structure such that the platen part is removed from the printer cabinet. Therefore, if any paper ejected from this printer is pulled away with an unnecessarily strong force, it may cause the platen gear to get off the track and damage the gear. Do not attempt to pull any paper ejected from the printer.

1.8 Wet paper can be make it jammed, pay attention to the following items when using the printer :

1.8.1 Turn off the power please when it is not used

1.8.2 Do not load any wet paper please.

1.8.3 Turn off the power to the head immediately when condensation occurs. Use the head only after the heads is completely dried. Depending on the environment where the printer is used ( the low temperature or high humidity), condensation may be caused by water vapor generated from the used paper when performing the printing of the high printing rate. Therefore, the environment should be considerably evaluated.

1.0 To separate the head and the platen after the paper run off, If the paper is run out during the printing, stop all actions of the printer in order to prevent the printing without the paper fed. If the printing is continued without any paper fed, it may cause the troubles of the printer.

1.10 When using this printer for the continuous actions, the temperature of the head printer board ( the detected temperature with the thermistor ) should be equal or less than 65 degrees centigrade for the temperature protection of IC inside of the printer as well as the surface temperature of the motor should be equal or less than 90 degrees centigrade for the temperature protection of the motor coil.

1.11 Make sure paper load smooth please.

1.12 Use the high quality thermal paper, for the property of the paper have big effect on printing quality. The perforated paper may cause the damage to the thermal heads and even shorten lifetime.

## Chapter 2 Specifications

### 2.1 General specifications

item	Specifications
	TP485A-H
Print method	Thermal dot line printing
Dots per line	384 dots
Resolution	8 dots/mm
Print width	48 mm
Papert width	57 f 1mm
W x D x H Åmm Å	67.4 x 30.8 x 32.2
Maximum printing speed	200 dot lines/s (25.0 mm/s) (at 5 V) <sup>1</sup> 450 dot lines/s (56.25 mm/s) (at 7.2 V) <sup>1</sup> 500 dot lines/s (62.5 mm/s) (at 8.0 V) <sup>1</sup>
Paper feed pitch	0.125mm
Head temperature detection	Via thermistor
Out-of-paper detection	Via photo interrupter
Life span (at 25°C and rated energy) Activation pulse resistance Abrasion resistance	100 million pulses or more (print ratio=12.5%) <sup>4</sup> 50 km or more
Operating temperature range ( )	0~40
Operating humidity (RH)	20 Å É 80 Å
Storage temperature range ( )	-25-70
Storage humidity ÅRH Å	10%-90

## 2.2 Heat element dimensions

TP485A contains a thermal head with 384 heat elements ( dot-size )

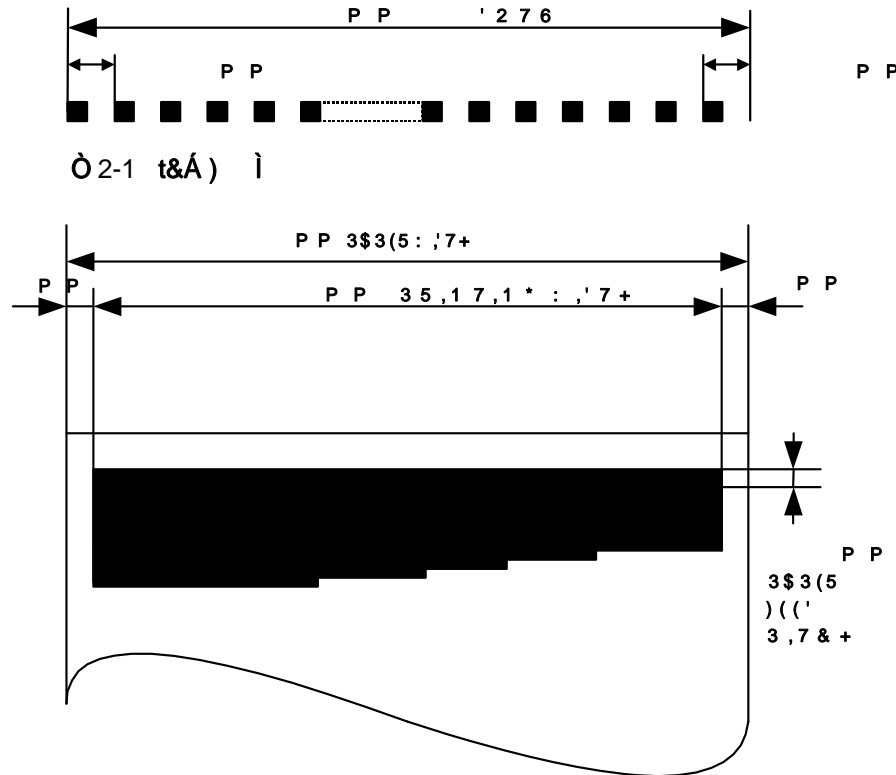

## 2.3 Paper feed characteristics

Paper is fed in a forward direction when the motor shaft is rotating in the normal direction ( clockwise ) when seen from the motor gear side.

The motor is driven by a 2-2 phase excitation, constant current chopper and method and feeds paper by 0.125mm ( equivalent to a single dot pitch ) every two steps of the motor drive signal.

To prevent deterioration in printing quality due to backlash of the paper feed system, the motor should be driven 40 steps in a reverse direction then 40 steps in the normal direction during initialization or following backward feeding .During paper feeding, the motor should be driven lower than lower than the value obtained by equation (1).

Equation(1)

At -5 or higher

$V_p \times 165 - 220(\text{pps})(\text{max.}1200(\text{pps}))$

Under -5

300 (pps)

During printing, motor drive frequency should be adjusted according to working conditions such as voltage, temperature, number of activated dots, etc.

Drive the motor at 200 pcs when automatically loading paper, regardless of the voltage. As for the motor current value, to keep the motor torque, activate the motor by only the first setting current value ( i.e one current) for the entire motor drive step time.

## 2.4 Step motor characteristics

## 2.4.1 Step motor specifications

Item	Specification
Type	PM
Number of phases	4-phase
Excitation	2-2 phase
Winding resistance per phase	10 $\pm$ 10%
Rated voltage	4.2~8.5V
Drive frequency	50-1200pps(Depends driving voltage)

## 2.4.2 Excitation sequence

Signal name	Sequence			
	STEP1	STEP2	STEP3	STEP4
A	high	high	low	low
/A	low	low	high	high
B	high	low	high	low
/B	low	high	low	high

## 2.4.3 Step motor driving

Low speed motor driving while printing due to a division drive method, print data, and input data transfer speed may cause noise or print trouble to occur due to over torquing or overheating of the motor. To prevent these from occurring, when using the printer at 5 or higher, be sure to set the motor current as follows and perform two-current control.

In low volatge We recommoned to use 6846 from Rohm and 1836, 1838 from Sanyo

## 2.5 Thermal head specifications

### 2.5 1 General characteristics

item	Operating humidity	Note
Print width	48 mm	
Number of heaters	384 dots	
Heater resolution	8 dots/mm	
Heater pitch	0.125 mm	
Printed dot dimension	0.11mm h 0.13 mm	
Heater resistance	R =176 $\pm$ 4%	H series $\hat{i}$ =123 $\pm$ 4%
Number of strobes	6	6
Logic power supply	3.3 V h 27 mA	at 5 MHz
	5.0 V h 60 mA	
Specification for Thermistor	R25=30K $\pm$ 5%,B=3,950K $\pm$ 3%	Table. 1

### 2.5 2 Maximum parameter

Parameter	Symbol	Specification	Note
Heater energy	Eomax	0.26 mJ/dot	2.5 ms/line

consumption		0.20 mJ/dot	1.25 ms/line
Head voltage	VH	10 V	Between Connectors
Logic voltage	Vdd	5.25V	
Environment temperature	Ta	-30 ~ +50	Above 5 recommended
Environment humidity		10 ~ 90%RH	
Maximum operating temperature	Ts	Continuous:65° C 30min. MAX.	When 80° C was detected, Printing must be stopped, and wait until 60° C
		Peak:80° C Thermistor temp.	

### 2.5 3 Characteristics recommended

Parameter	Symbol	Recommended operating conditions		Note	
Speed		2.5 ms/line	1.25 ms/line		
Heater power consumption	Eo	0.12W/dot	0.25W/dot	R=176 i	
Heat voltage	VH	5.0V	7.2V	connect two ends	
Heater energy consumption	5	Eo (ts)	0.2mJ/dot(1.6ms)	0.17mJ/dot(0.65ms)	64 dots heated meanwhile
	25		0.18mJ/dot(1.4ms)	0.14mJ/dot(0.54ms)	
	40		0.16mJ/dot(1.28ms)	0.13mJ/dot(0.50ms)	
Supply current	Io	26.6mA/dot	38.3mA/dot	R=176 i	

## 2.5 4 Electrical characteristics

Parameter	symbol	Test conditions	Min.	Typ.	Max.	unit
Supply voltage	V <sub>H</sub>		4.2	5	8.5	V
Supply voltage	V <sub>dd</sub>		3.0	5.0	5.5	V
Logic supply current	I <sub>dd</sub>	f <sub>CLK</sub> =8MHz SI=1/2 f <sub>CLK</sub>		21	60	mA
Input voltage for logic	V <sub>IH</sub>		0.8V <sub>dd</sub>		V <sub>dd</sub>	V
	V <sub>IL</sub>				0.2 V <sub>dd</sub>	V
Clock frequency	f <sub>CLK</sub>	Duty50%			8	MHz
Input current	LATCH	V <sub>dd</sub> =5.0V V <sub>IH</sub> =5.0V			3.0	- A
	STROBE				55	
	CLOCK				3.0	
	DATAIN				0.5	
	LATCH	V <sub>IL</sub> =GND	-330			- A
	STROBE		-0.5			
	CLOCK		-3.0			
	DATAIN		-0.5			
Output voltage of drivers (Heater supply voltage)	V <sub>OL</sub>	V <sub>dd</sub> =3V, I <sub>OL</sub> =60mA		0.7	0.9	V
Leak current of drivers	I <sub>LEAK</sub>	V <sub>OH</sub> =8V			1.0	- A/dot
Logic supply current	I <sub>dd</sub>	f <sub>CLK</sub> =5MHz, S=1/2 f <sub>CLK</sub>		21	60	mA
"H"Level output	V <sub>OH</sub>	I <sub>OH</sub> =-0.5mA	2.6			V
"L"Level output	V <sub>OL</sub>	I <sub>OH</sub> =0.5mA			0.4	V

## 2.5 5 Timing characteristics

Parameter	Code	Ratings			unit.
		Min.	Typ.	Max.	
Clock frequency	$f_{MAX}$			8.0	MHZ
Clock pulse width	$t_w(T)$	50			Ns
Data setup time	$t_{su}(D)$	40			ns
Data hold time	$t_h(D)$	40			ns
Latch setup time	$t_{su}(LA)$	100			ns
Latch pulse width	$t_w(LA)$	100			ns
Clock to So delay time	$t_d(SO)$			120	- s
Strobe to driver Output delay time	$t_d(DO)$			26.0	- s

## 2.5 6 Timing figure

**2.5.7 Equation:**

Calculate the printing energy using this equation;

**2.5.8 Circuit recommended**

## 2.5.9 Thermistor resistance

Temperature ( ° C )	Thermistor Resistance (R)		
	Min.(K <sub>i</sub> )	Typ.(K <sub>i</sub> )	Max.(K <sub>i</sub> )
-40	717	843	989
-35	535	623	487
-30	405	466	535
-25	308	352	400
-20	238	269	303
-15	185	208	232
-10	145	161	178
-5	113	124	137
0	88.7	96.8	105
5	69.9	75.7	81.7
10	55.4	59.5	63.8
15	44.1	47.1	50.1
20	35.4	37.5	39.6
25	28.5	30	31.5
30	22.8	24.2	25.5
35	18.3	19.6	20.8
40	14.9	15.9	17.1
45	12.1	13.1	14.1
50	9.92	10.8	11.7
55	8.16	8.91	9.7
60	6.76	7.41	8.12
65	5.62	6.2	6.83
70	4.7	5.21	5.77
75	3.95	4.4	4.9
80	3.34	3.74	4.18

## 2.5.10 Structure figure

## 2.5.11 Operating precautions

1 When the power on, the order shall be VDD-VH, and make sure strobe is the lowest,. When the power off, it should be VH –VDD .

2 Set time limits on circuit, make strobe low automatically when it is abnormal or system halted.

3. For the waiting time, control ( circuit design) the printer so that VH (power supply of the heating element) is turned off ( the GND level ) in order to prevent thermal printer head damage by ions and noises.

4. When the thermistor is disconnected , control (circuit design) the printer head is not overheated.

5. Do not input any pulse noise of equal or more than 2V É 20ns in each signal.

6.Do not input any pulse noise of equal or more than 2V, 20ns in each signal terminal.

7 Make sure not to condense dews on the head. If condensation occurs on the head, maintain the VH power supply in the off state until condensation has been solved.

## 2.6 Tables

1	PHK	Cathode for photo interruptor
2	VSEN	Paper sensot power
3	PHE	Emittor for photo interruptor
4	MT/B	Step motor excitation signal
5	MT/B <sup>-</sup>	Step motor excitation signal
6	MT/A	Step motor excitation signal
7	MT/A <sup>-</sup>	Step motor excitation signal
8	VH	Head drive power
9	VH	Head drive power
10	DI	Data in
11	CLK	Aynchronous clock for communication
12	GND	Ground power supply for thermal head
13	GND	Ground power supply for thermal head
14	STB6	Thermal head energizing control signal
15	STB5	Thermal head energizing control signal
16	STB4	Thermal head energizing control signal
17	VDD	Logic power
18	TM	Thermally sensitive resistor input terminal 1
19	TM	Thermally sensitive resistor input terminal 2
20	STB3	Thermal head energizing control signal
21	STB2	Thermal head energizing control signal
22	STB1	Thermal head energizing control signal
23	GND	Ground power supply for thermal head
24	GND	Ground power supply for thermal head
25	/LAT	Data latch
26	DO	Data out
27	VH	Power supply for thermal head
28	VH	Power supply for thermal head
29	N.C(101)SW1(103)	Platen release switch
30	N.C(101)SW2(103)	Platen release switch

## 2.7 Photo interpreter specification

TP485 have one photo sensor, it performs dual functions - door open and end of paper detection. The photo sensor is designed in a way that as soon as the door is opened, the distance between the paper and the sensor increases, and this causes the end of paper sensor is to trigger.

Arrange the circuitry so that no energy is applied to the head when there is no paper. If the head is energized when there is no paper and the head is in the down position, then both roller and head may be strongly damaged. Å

One possible interface as following:

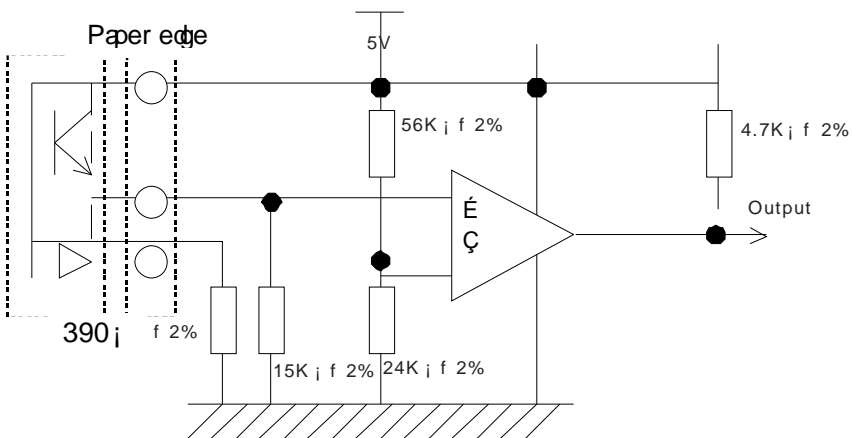

## Absolute Maximum Ratings (Ta=25)

Parameter		Symbol	Ratings	Unit
Input	Power Dissipation at(or below) 25 Free Air Temperature	Pd	75	mW
		V <sub>R</sub>	5	V
	Forward Current	I <sub>F</sub>	50	mA
	Peak Forward Current Pulse width ≤ 100 μs, Duty cycle=1%	I <sub>FP</sub>	1	A
Output	Collector Power Dissipation	P <sub>C</sub>	75	mW
	Collector Current	I <sub>C</sub>	50	mA
	Collector-Emitter Voltage	B V <sub>CEO</sub>	30	V
	Emitter-Collector Voltage	B V <sub>ECO</sub>	5	V
Operating Temperature		T <sub>opr</sub>	-25~+85	°C
Storage Temperature		T <sub>stg</sub>	-40~+85	°C
Lead Soldering Temperature (1/16 inch from body for 5 seconds)		T <sub>sol</sub>	260	°C

(\* 1)  $t_w=100 \mu \text{ sec.}$  ,  $T=10 \text{ msec.}$  (\* 2)  $t=5 \text{ Sec}$

## Electro-Optical Characteristics (Ta=25)

Parameter		Symbol	Min	Typ.	Max.	Unit	Conditions
Input	Forward voltage	V <sub>F</sub>		1.2	1.6	V	I <sub>F</sub> =20mA
	Reverse Current	I <sub>R</sub>			10	μA	V <sub>R</sub> =5V
	Peak wavelength	λ <sub>P</sub>		940		nm	
	View Angle	2θ <sub>1/2</sub>		110		Deg	I <sub>F</sub> =20mA
Output	Dark Current	I <sub>CEO</sub>			100	nA	V <sub>CE</sub> =10V
	C-E Saturation Voltage	V <sub>CE (sat)</sub>			0.4	V	I <sub>C</sub> =2mA I <sub>B</sub> =0.1mA
Light Current		I <sub>C(ON)</sub>	0.1			mA	V <sub>CE</sub> =5V I <sub>F</sub> =20mA
Leakage Current		I <sub>CEOD</sub>			1	μA	
Speed	Rise time	t <sub>r</sub>		20		μsec	V <sub>CE</sub> =2V I <sub>C</sub> =100μA
	Fall time	t <sub>f</sub>		20		μsec	R <sub>L</sub> =1KΩ



## Chapter 3 Casing design guide

### 3.1 Thermal printer mechanism structure dimensions

#### 3.1.1 Easy paper loading dimensions

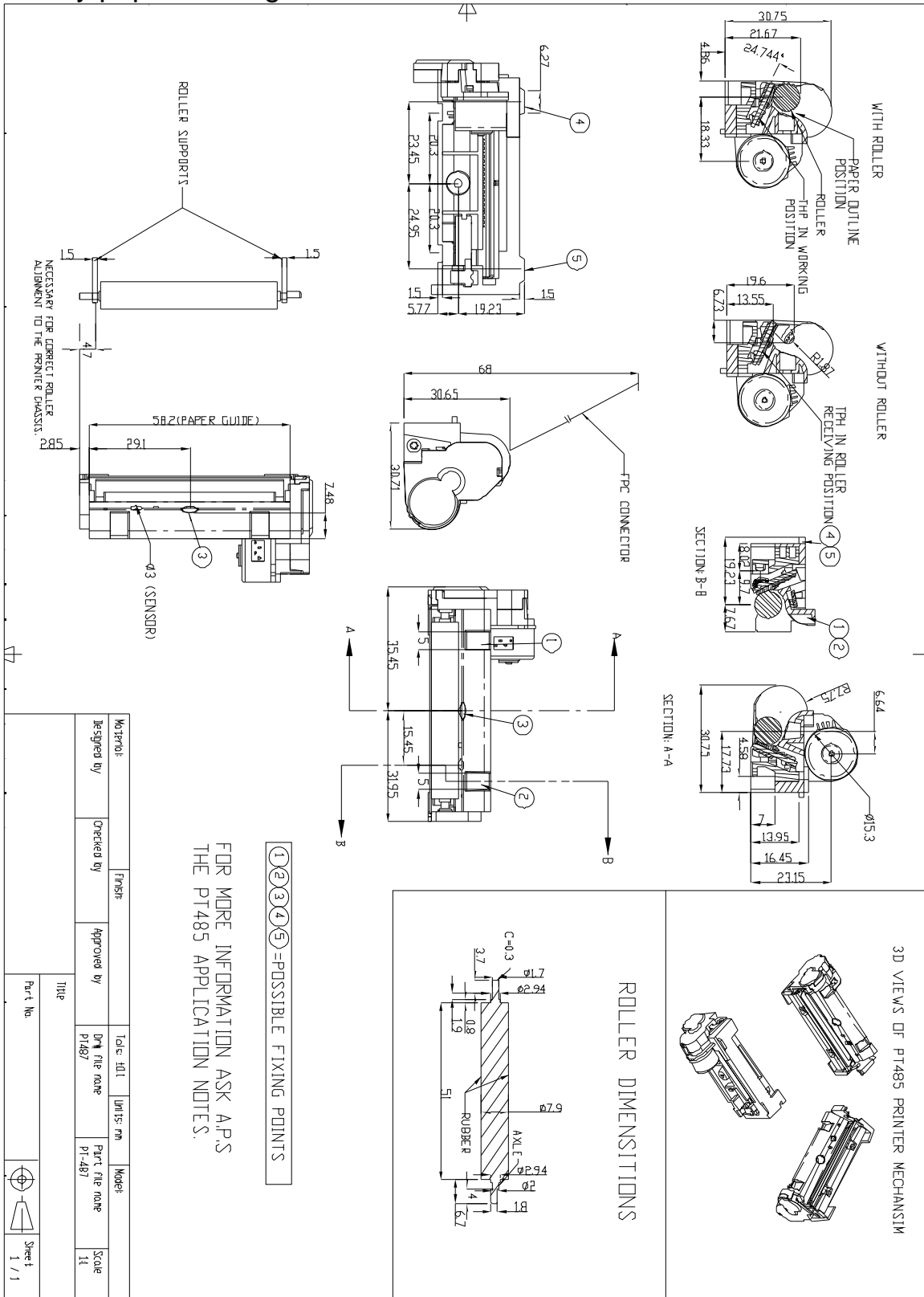

3.1.2 Roll-paper mounting position

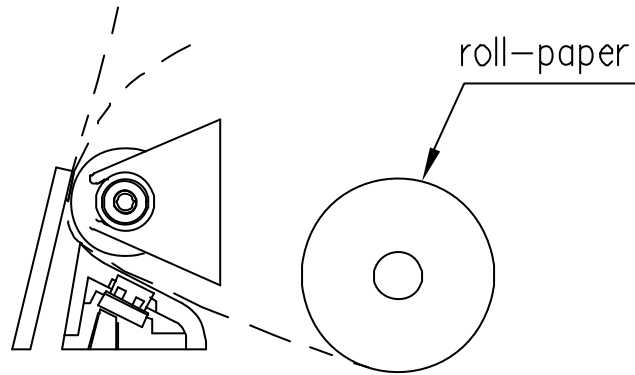

Wrong mounting

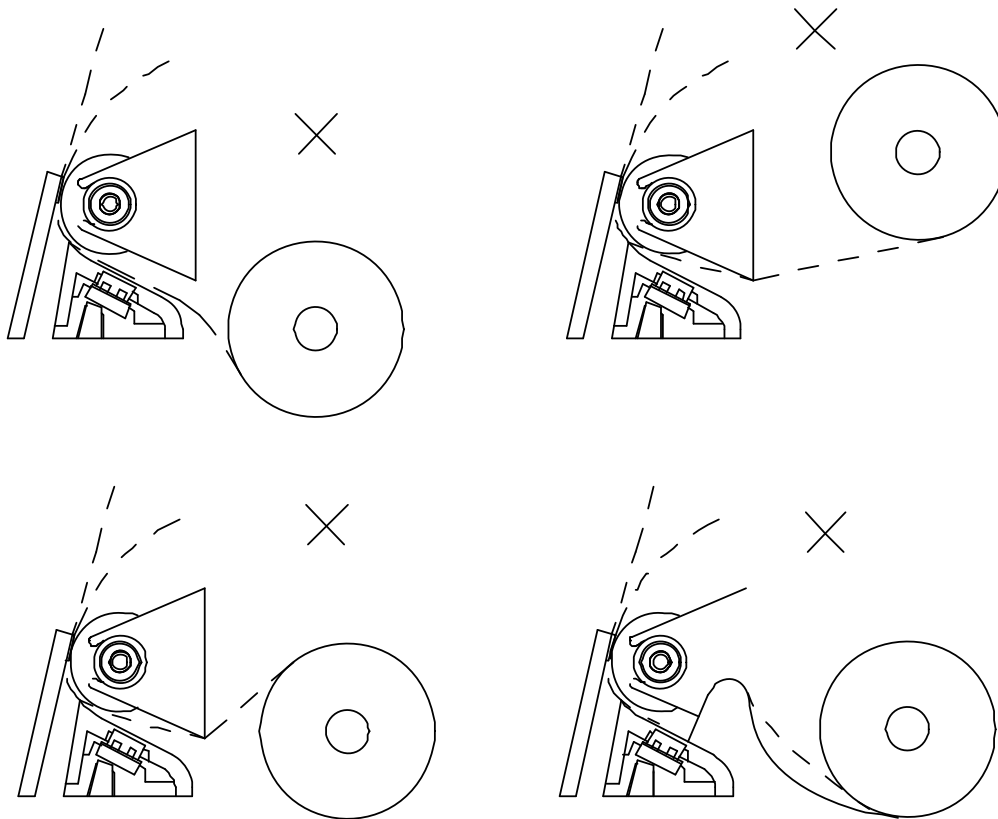

## 3.2 DEMO circuit figure

### Circuit definition

1. This Demo controls printer by bus.
2. Bus supports 3.3V and 3.5V system.
3. When designing circuit, make powering on VH (7V) later than that of the system (5V) and PMOS is recommended to add to VH.
4. In printing, triaacer output high/low pulse is recommend to prevent the svstem mistake and damages to the printer.